

FACETED DIAMOND

A (MM - INCH)

CONICAL

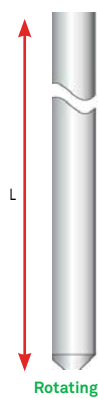

- 77659
- 34122
- 34123
- 34124

- 0.25
- 0.25
- 0.38
- 0.76

- .010"
- .010"
- .015"
- .030"

- 130mm/5.118"
- 160mm/6.299"
- 160mm/6.299"
- 160mm/6.299"

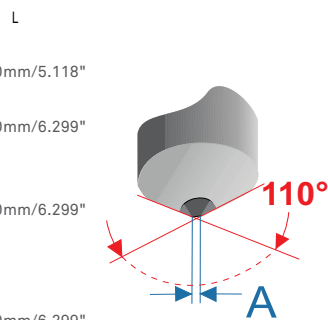

FACETED DIAMOND

FACETED DIAMOND

COMPATIBLE MATERIALS

- Plastics
- Leathers and derived products
- Glass & Mirror
- Aluminium/Brass
- Gold/Silver
- Steel/Stainless steel
- Absolutely suitable

-
-
-
-
-
-

Designed for Feather Touch Use

1 1/64" (4.36 mm) SHANK SIZE

BALL DIAMOND

A (MM - INCH)

SPECIAL DIAMOND

A (MM - INCH)

CONICAL DIAMOND

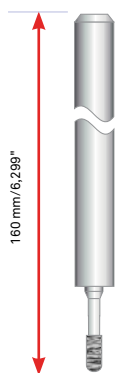

- 20932
- 20933

- 1.60

- .063"

- 0.09"

- 2.30

- 34121

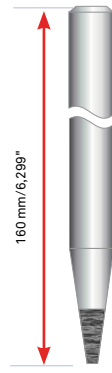

Rotating

Non Rotating

Designed for Feather Touch Use

SPECIAL

DIAMOND BALL

DIAMOND CONICAL

COMPATIBLE MATERIALS

- Plastics
- Leathers and derived products
- Phenolic
- Steel/Stainless steel
- Glass & Mirrors
- Granite
- Absolutely suitable

-
-
-
-
-
-

SCRIBING DIAMOND

A (INCH - MM)

DIAMOND

Scribing diamond
Non Rotative
 Engraving on ferrous metal and non ferrous metal.
 Pantograph IR & IRV
 CN machines using a 6.35mm collet spindle.

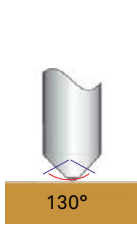

- .004"

- 0.10

- 34261 (11890)

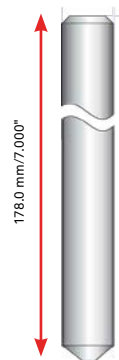

Rotating

Non Rotating

SCRIBING DIAMOND

DIAMOND

COMPATIBLE MATERIALS

- Glass & Mirrors
- Gold/Silver
- Aluminium/Brass
- Steel/Stainless steel
- Absolutely suitable

-

1/4" (6.35 mm) SHANK SIZE

$\theta = 120^\circ$ DIAMOND

A (MM - INCH)

CONICAL

A (INCH - MM)

DIAMOND

$\theta = 126.5^\circ$

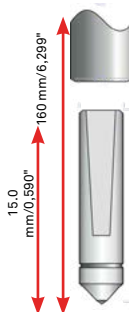

- 23060

- 0.10

- .004"

120.0°

126.5°

- .004"

- 0.10

- 23061

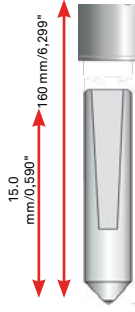

Rotating

Non Rotating

DIAMOND

COMPATIBLE MATERIALS

- Gravoply™, Metallex™ & Gravoglas™, Acrylic
- Gold/Silver
- Aluminium/Brass
- Steel/Stainless steel
- Absolutely suitable

- $\theta = 120.0^\circ$
- $\theta = 126.5^\circ$
-
-
-
-

TWINCUT